

VMP014/024

large television wall & ceiling mount

Product Features:

rotates 260° (wall) / 360° (ceiling)

adjustable 0° to 15° tilt

opens from 17" to 32" (left to right)

opens from 15.75" to 26.25 (top to bottom)

mast telescopes 18" to 30" from ceiling

holds most 20" to 29" televisions /
maximum monitor depth 23"

load capacity - 165 lbs

black powder coat finish

Product Specifications:

(for Architects & Engineers)

The wall/ceiling mount for the TV/monitor shall be a Video Mount Products (VMP) model VMP 014/024. The monitor mount shall be constructed primarily of tubular steel and shall incorporate nylon filled nuts and arc welds. The monitor mount shall be designed to allow adjustable tilt up to a maximum of 15° and must swivel 260° when wall mounted and 360° when ceiling mounted. The monitor mount shall have adjusting dimensions capable of holding a TV/monitor with screen sizes from 20" to 29". The mount shall open 17" to 32" (left to right) and open 15.75" to 26.25" (top to bottom). The monitor mount shall have an integrated clamping mechanism that will secure the monitor on all sides. The load capacity shall be 165 lbs. The monitor mount shall be UL listed in the United States and Canada.

Video Mount Products

325 Log Canoe Circle

Stevensville, MD 21666

Phone: 410.643.6390

Fax: 410.643.6615

www.videomount.com

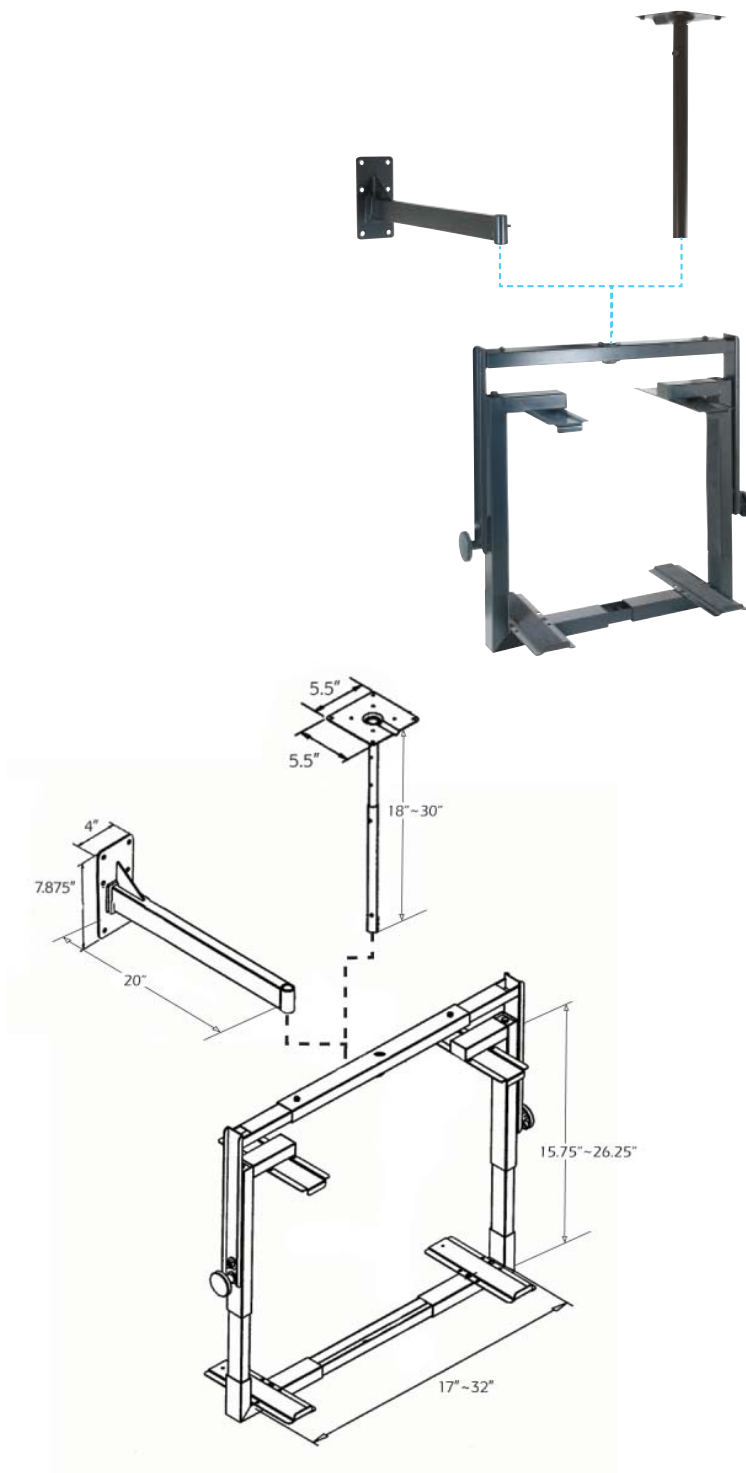

VMP
VIDEO MOUNT PRODUCTS

