

# ERVWC-2U Series

2U Vertical Equipment Wall Cabinet

## Product Features:

- Ships Fully Assembled
- Two convenient 2U cabinet depths
  - 20" Usable Vertical Depth (ERVWC-2U20)
  - 36" Usable Vertical Depth (ERVWC-2U36)
- Rails adjust to accommodate mounting depth
- Reversible front door – Vented for cooling
- Locking hinged body
- .5" and 75" top and bottom cable ports
- Threaded Mounting holes – M6 or 12-24
- Marked rack spaces
- Slide out 1U bracket for patch panels
- Load Capacity 150 lbs.
- Black Finish

## ERVWC-2U36 (Shown)

Overall Dimensions: 42.6"H x 25.3"W x 4.5"D

## ERVWC-2U20

Overall Dimensions: 28.7"H x 25.3"W x 4.5"D

## Product Specifications:

*(for Architects & Engineers)*

The wall mounted vertical equipment cabinet is the Video Mount Products (VMP) model number ERVWC-\_\_\_\_. The equipment cabinet shall be primarily constructed of formed steel. The equipment rack shall be compatible with standard 19" EIA rack equipment. The equipment cabinet shall be available in 20" (ERVWC-2U20) and 36" (ERVWC-2U36) usable depths and able to be wall mounted vertically. The equipment cabinet shall include a reversible front door, rear cable pass-throughs, and the reversible rail channels shall be tapped with 12-24 and M6 holes in universal E.I.A. spacing. The equipment rack shall have a load capacity of 150 lbs. and shall be painted with a durable static resistant black powder coat finish.

## Video Mount Products

345 Log Canoe Circle Stevensville, MD 21666  
Toll Free: 877.281.2169 Telephone: 410.643.6390  
Facsimile: 410.643.6615 [www.videomount.com](http://www.videomount.com)

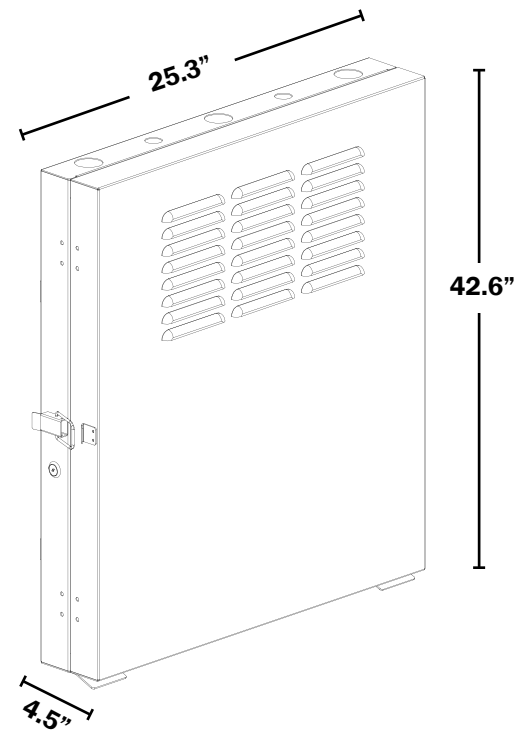

**VMP**  
VIDEO MOUNT PRODUCTS