

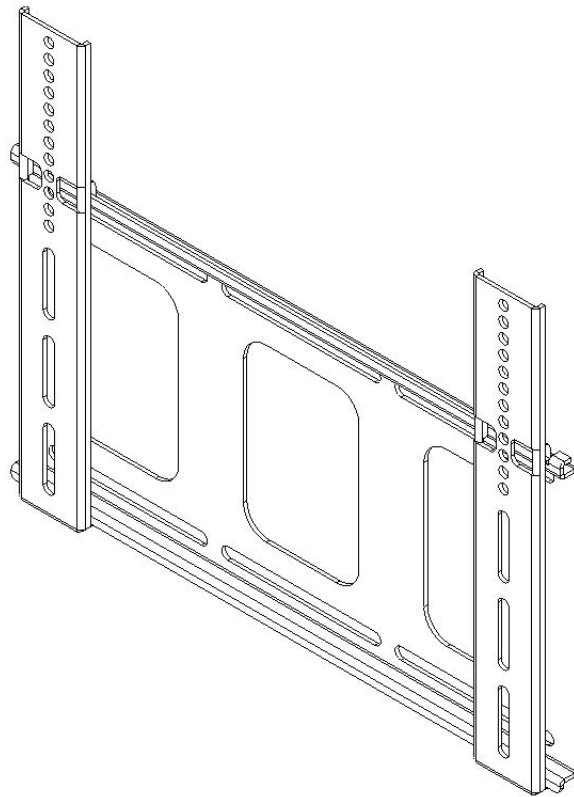

Instruction Sheet For:

LCD-MID-F & LCD-MID-FB



For more information, please contact us at:
345 Log Canoe Circle, Stevensville, Maryland 21666
Toll Free: 877.281.2169 Phone: 410.643.6390 Fax: 410.643.6615
www.videomount.com

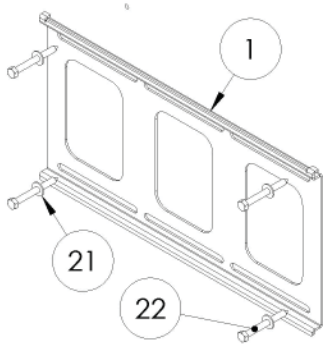

Step 2: Mounting the wall plate

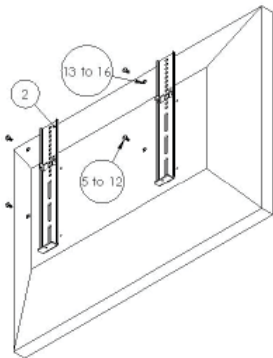

Step 3A: Attaching the mounting brackets to the monitor (spacers not needed)

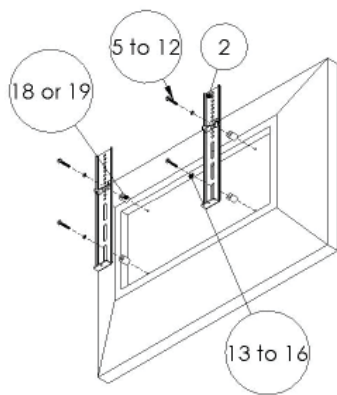

Step 3B: Attaching the mounting brackets to the monitor (spacers used due to recessed hole patterns)

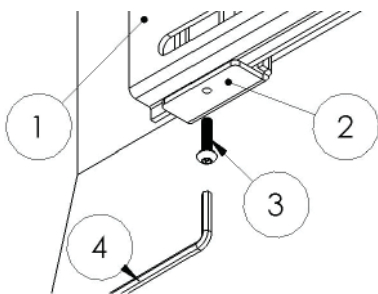

Step 4: Securing the mounting brackets to the wall plate

Step 1

Before starting, lay out all parts to your mount and match them to the parts list provided. Verify that you have all your parts before attempting to assemble the mount.

Step 2

Mark the wall or desired mounting surface in preparation of installation of wall plate (1). If mounting to wooden studs, pre drill pilot holes using a 7/32" drill bit. Attach the wall plate (1) to the wooden stud using the 5/16" by 2.5" long lag screw (22) and washer (21) making sure the small ear flaps are on the top rail of the wall plate (1). **WARNING: Please verify that your mounting surface will support the combined weight of your mount, mounting hardware, and flat panel. Also verify that the mounting surface is safe to drill through. Please note only mounting hardware for mounting to wooden studs will be provided with the unit. If mounting to a surface other than wooden studs then other hardware will be required. If in doubt or uncertain about any of the above, please contact a professional installer.**

Step 3

Determine the correct screw size and if you need to use washers, lock washers, or spacers. *Note: Spacers are used for TVs with recessed hole patterns.* Secure the TV to the mounting bracket (2) using the appropriate hardware (5) through (19). *Note: The brackets have to be level with each other to work properly.*

Step 4

Use the hooks in the mounting bracket (2) to hook on the top rail of the wall plate (1). Use security screws (3) and the long allen key (4) to secure the TVs to the wall plate (1) and to secure its horizontal position.

Please verify that all nuts and screws are securely tightened.



Enjoy Your Mount!

WARNING: The installer of these products must verify that the mount surface, ceiling or wall, will safely support the combined weight of all attached equipment and hardware. Video Mount Products will not be held liable for the improper use or installation of its products.