

# DS-CH

Digital Signage Computer or Component Holder

## Product Features:

Used to securely attach a digital signage computer or other component to a wall or ceiling mount

Attaches to mounting rails in landscape or portrait positions to better hide behind the flat panel

Utilizes tamper resistant hardware

Works with VMP models FP-LDSB, PDS-LC and PDS-LFT as well as most other manufacturer's mounts

Interior dimensions – 11" x 7" x 2.375"

Black powder coat finish

## Product Specifications:

*(for Architects & Engineers)*

The digital signage computer holder shall be the Video Mount Products (VMP) DS-CH. The holder shall be capable of attaching to the mounting rails of a wide variety of wall and ceiling mounts provided there is sufficient space for the holder to reside. The holder shall be attachable in both portrait and landscape as to better hide behind the flat panel in a variety of mounting situations. The holder shall be primarily constructed of formed steel and shall incorporate security screws and arc welds. The holder shall be vented to allow the computer to dissipate heat as well as have cable pass throughs in the top and bottom. The holder shall have dimensions of 11" by 7" by 2.375".

## Video Mount Products

345 Log Canoe Circle

Stevensville, MD 21666

Toll Free: 877.281.2169

Telephone: 410.643.6390

Facsimile: 410.643.6615

[www.videomount.com](http://www.videomount.com)

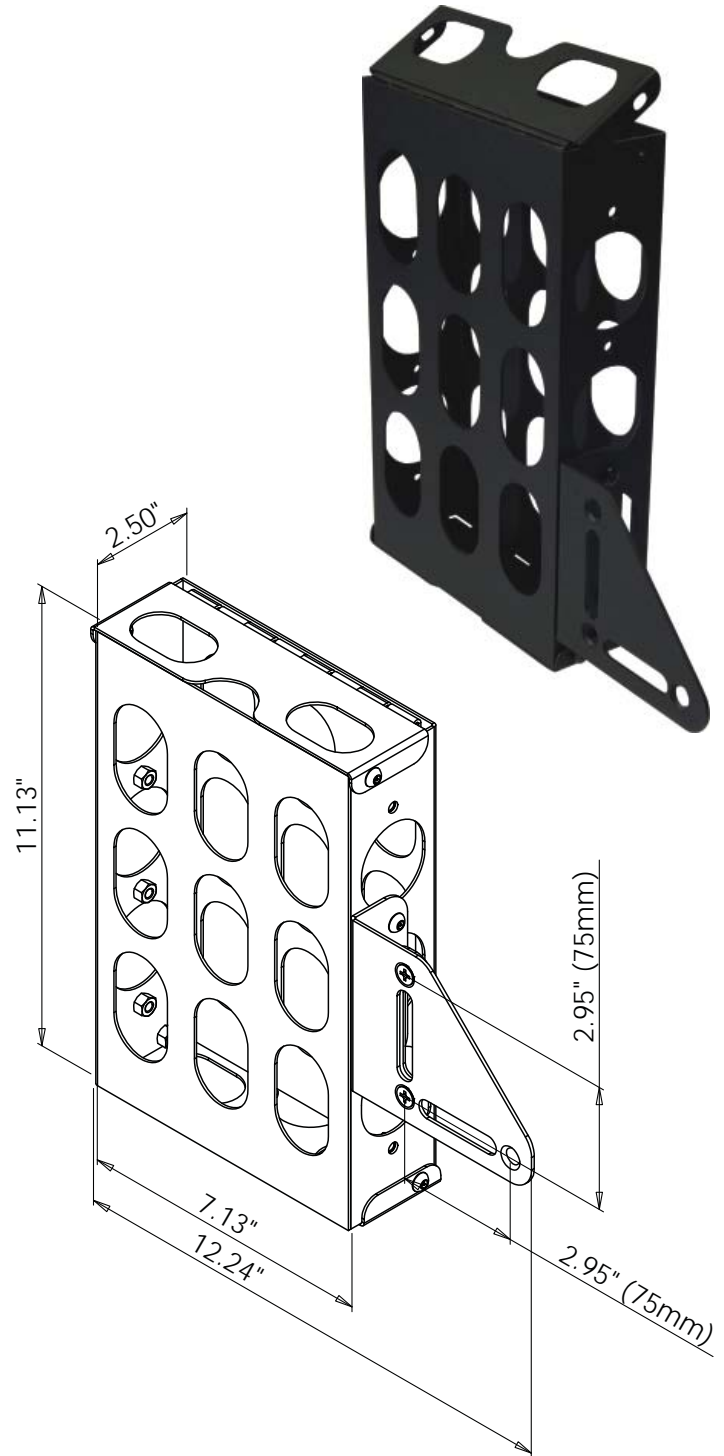

**VMP**  
VIDEO MOUNT PRODUCTS