

ER-8RSA

Adjustable Eight Receiver Rack Shelf

Product Features:

Accommodates up to eight receivers

Adjusts left to right and front to back

Includes front and top anti-roll bars

Includes 10-32 and 12-24 rack screws

Load capacity – 50 lbs

Black powder coat finish

US Patent #: 7,850,022

Product Specifications:

(for Architects & Engineers)

The equipment rack shelf shall be the Video Mount Products (VMP) model ER-8RSA. The shelf shall be compatible with standard 19" equipment racks without modification. The shelf shall fit all components up to 17.375" in width. The shelf shall include front and top anti-roll bars and 7 shelf dividers. The shelf shall be painted with a durable black powder coat finish. The load capacity shall be 50 lbs.

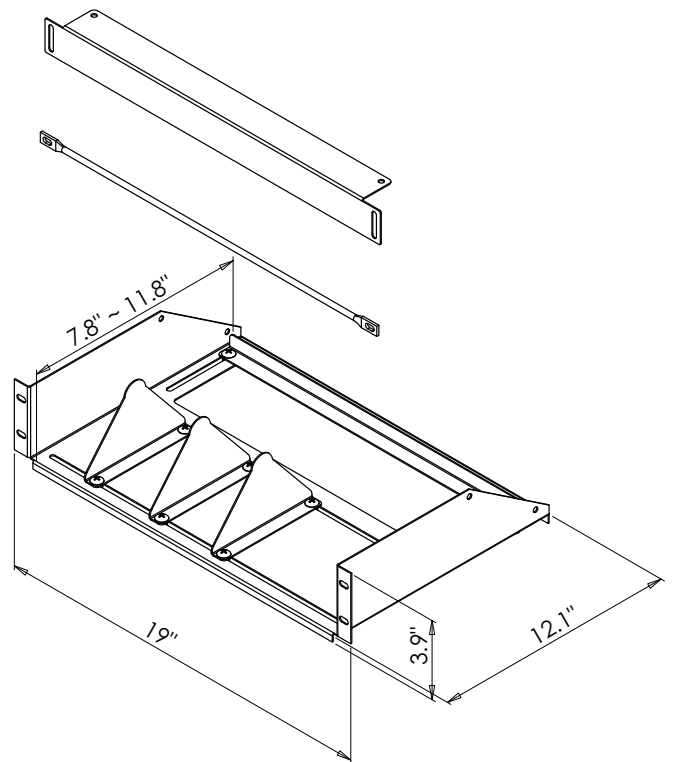

Video Mount Products

345 Log Canoe Circle

Stevensville, MD 21666

Toll Free: 877.281.2169

Telephone: 410.643.6390

Facsimile: 410.643.6615

www.videomount.com

VMP
VIDEO MOUNT PRODUCTS