

VH-005

Pipe/Ceiling Mast Electronic Component Holder

Product Features:

Works with all VMP ceiling mounts and works with all manufacturer's ceiling mounts using masting from 1" to 2" O.D.

Accommodates DVD players, CD players, DVR's, HD receivers, and other electronic components

Mounting U "tray" extends 13" from the pipe

Includes decorative plastic covers

Load capacity – 25 lbs

Silver powder coat finish

Also available in black finish (VH-005B)

Product Specifications:

(for Architects & Engineers)

The electronic component holder for pipe/ceiling mounts shall be the Video Mount Products (VMP) model VH-005. The mount shall be primarily constructed of formed steel. The mount shall be mountable to pipe/ceiling masts from 1" OD to 2" OD. The mounting "U" tray shall extend 13" from the pipe attachment point. The load capacity shall be 25 lbs. The mount will also be available in a black scratch resistant powder coat finish (VH-005B).

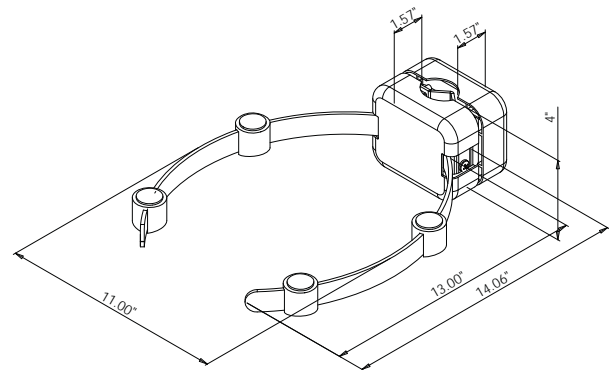

Video Mount Products

345 Log Canoe Circle

Stevensville, MD 21666

Toll Free: 877.281.2169

Telephone: 410.643.6390

Facsimile: 410.643.6615

www.videomount.com

VMP
VIDEO MOUNT PRODUCTS